

Motor M42/I with planetary gear P32

- Steel gearhousing, aluminium gearflange
- Other reductions, output shaft or connection cable on request

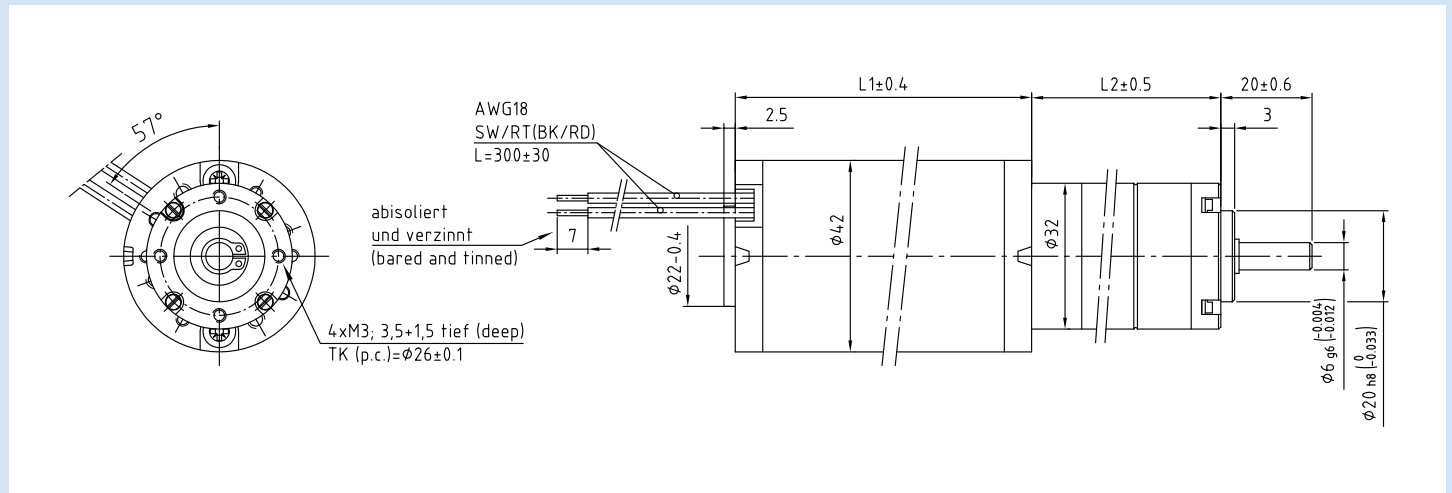

Gear reduction table M42xXX/I+ P32

Application on request

Gear reduction	Number of gear stages	Efficiency of the gear	Speed at motor-speed 3000rpm	Continuous torque			
				M42x15/I L1 = 70 mm	M42x20/I L1 = 75 mm	M42x30/I L1 = 85 mm	M42x40/I L1 = 95 mm
[i = x:1]	[x]	[%]	[1/min]	[Ncm]	[Ncm]	[Ncm]	[Ncm]
3.7	1	80	800	11,8	14,8	19,2	26,6
7	1	80	430	22,4	28	36,4	40
14	2	75	215	42	52,5	68	94,5
25	2	75	120	75	94	122	168,7
46	2	75	65	138	173	224	310
93	3	70	33	260	325	423	585
169	3	70	18	473	592	770	1064
308	3	70	10	862	1078	1400	1940

*) Motor have to be operated with current limitation

General gear data

	[x]	1	2	3
Number of gear stages	[x]	1	2	3
Maximum torque	[Ncm]	75	225	450
Permissible shaft load	[N] (axial / radial)	10 / 40	20 / 70	30 / 100
Gear length L2	[mm]	21,3	30,8	40,3

Stand: 4. August 2020 – changes reserved