

Magnetic Encoder IGM x/y for series M63/M80

- Touchless and wear resistant magnetic incremental encoder
- Two AB Signals
- Velocity: 1 to 30.000 RPM

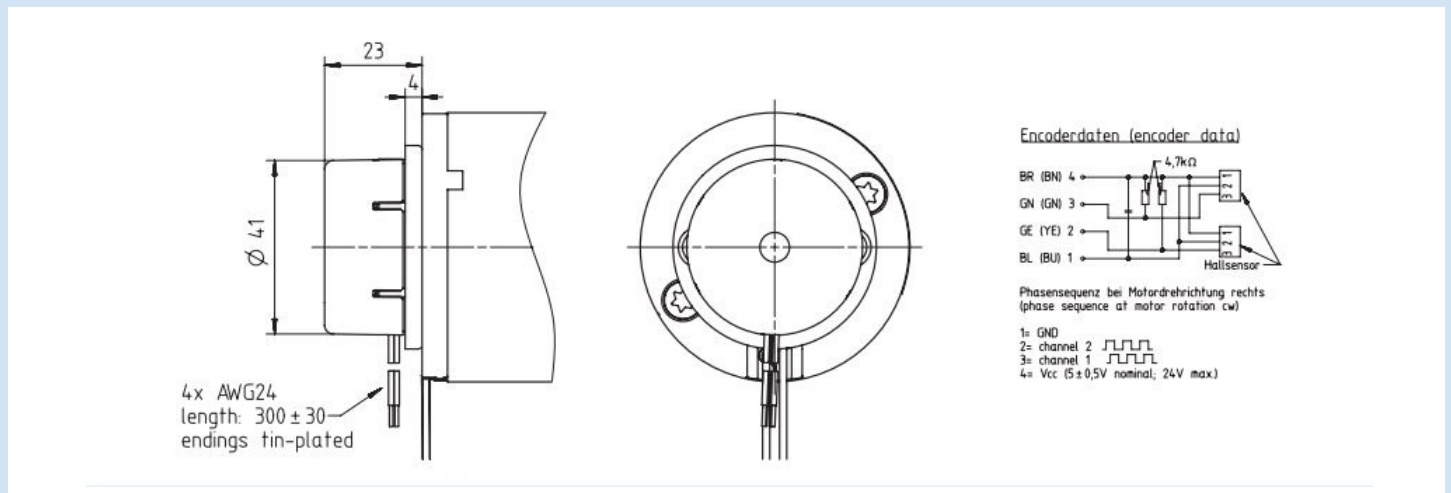

Technical data

Application on request

Impulses per revolution	[x]	1*, 2, 4, 8, 12, 15*
Channels	[y]	1, 2
Supply voltage	[V]	5 - 24
Current consumption	[mA]	7 - 13
Open-Collector-Output	[kOhm]	4,7
Output-voltage High-Level minimal	[V]	$V_{cc} - (I_{Last} * 4,7kOhm)$
Output-voltage Low-Level maximal	[V]	max. 0,4
Rise-Time	[ns]	1400
Fall-Time	[ns]	60
Temperature range	[°C]	-40 - 100

*) only 1 channel

Update: 21.03.2024 – changes reserved